

sage

Accpac
ERP

Contents

- 1 **Scalable Business Management Software**
- 2 **Overview of Benefits**
- 3 **Choosing the right Sage Accpac ERP Edition for your Business**
- 4 **Sage Accpac ERP Feature Comparison**
- 5 **A Breakdown of Core Modules**
 - 5 System & User Administration
 - 6 Financial Modules
 - 8 Purchasing Modules
 - 9 Stock Management Modules
 - 10 Sales and Receivables Modules
 - 12 Project Management Modules
- 13 **A Host of Additional Modules...**

Scalable Business Management Software

At Sage, we've been supporting businesses like yours with world-class business software for well over a quarter of a century. Our long-term commitment to investing in technologies and applications helps you to stay ahead in a rapidly changing world.

Many of your suppliers and associates are already drawing on their Sage software, to achieve more, faster than before and at a lower cost. Choose Sage as your strategic partner and you'll join over 5.4 million organisations across the world.

Sage Accpac ERP is a web-based, enterprise application designed for the global marketplace. It is multi-platform, database independent software which is currently available

in over 70 countries worldwide. From single user installations to large corporate environments, Sage Accpac ERP has the scalability, flexibility and reliability to suit all your business needs. System-wide multicurrency functionality, compliance with many varied local accounting requirements, and a comprehensive global distribution and support base provides the ideal product for the internationally orientated company.



“At Sage, we understand that mid-sized and larger businesses have varied and complex requirements. From accounting and payroll through to CRM and ERP, we offer scalable, integrated software to meet their needs.”

Paul Stobart,
CEO, UK and Ireland Region, Sage (UK) Limited

Overview of Benefits

■ **Exceptional multi-lingual and multi-currency capabilities**

Sage Accpac ERP is a leading software application in many of the world's major global economies. It has been translated into a number of languages and is fully supported by a network of accredited local partners across more than 70 countries. Alongside this, sophisticated currency management and the ability to process transactions in any number of currencies give your business the global competitive edge required in today's business world.

■ **Scalable with a simple upgrade path**

From single-user remote locations to large corporate environments with demanding accounting needs, Sage Accpac ERP offers complete scalability. There are 3 Sage Accpac editions to choose from. When your business grows, and you need to add more users or capacity, you can just move up to a higher edition. All Sage Accpac editions have an identical user interface, screens and modules – meaning upgrades don't involve costly staff retraining or data conversion. Sage Accpac also enables data processing across multiple servers, to share the processing load as your number of users increases.

■ **Efficient and easy to use**

Thanks to a highly intuitive and consistent graphical interface, learning Sage Accpac ERP is quick and easy. All the modules have the same look and feel: so once you learn how to move through one module, the learning curve is short for the others. This makes data entry, analysis, and reporting simple and logical, even for a new user.

■ **Fully customisable**

Sage Accpac allows you to personalise your desktop at an individual user level. A credit control clerk, for example, can optimise productivity with a desktop modification that provides easy access to accounts receivable functions. Similarly, a manager can then customise that desktop to hide confidential bank account information. You can design and add unlimited optional fields to your entire Sage Accpac system with the Transaction Analysis and Optional Field Creator. Also, using Sage Accpac Options, a set of reporting, analysis, automation, and feature extension tools, can even further increase functionality.

■ **Part of an integrated business management suite**

Sage Accpac integrates with an array of end-to-end applications, including Sage CRM, Sage Accpac Exchange – an EDI solution that helps you connect electronically with your suppliers and customers, and Sage Accpac WMS – a warehouse management solution. We also partner with more than 400 developers who create and market a wide range of applications that enhance and extend Sage Accpac for specific industries and special business needs.

■ **Advanced web and wireless architecture**

When choosing a business management system, you are making an investment in your future. Selecting a product with high quality architecture, such as Sage Accpac, will ensure investment protection. That's because high quality architecture stands the test of time - quickly adapting to new technologies and easily integrating external applications for effective information exchange. It is Sage Accpac's object-oriented and multi-tiered architecture that makes the product so flexible. Since all Sage Accpac editions share the same architecture and code base, valuable transaction history can easily be retained when you upgrade.

■ **Choice of deployment options**

The whole range of Sage Accpac solutions can be deployed on a wide range of databases and operating systems. Please see the feature comparison on page 4 for further details.

Choosing the right Sage Accpac ERP Edition for your Business

Sage Accpac ERP is available in three different editions: Sage Accpac 100 ERP, Sage Accpac 200 ERP and Sage Accpac 500 ERP. With three editions to choose from, you don't have to worry about outgrowing your system. As your business grows, moving up to a higher edition is straightforward with easy data migration and consistent look and feel. All editions have the same core modules - just choose the one that is right for your business.

Core Sage Accpac ERP Modules

- System Manager
- General Ledger
- Accounts Receivable
- Accounts Payable
- Inventory Control
- Order Entry
- Purchase Orders
- Project & Job Costing
- Multi-currency
- Transactional Analysis and Optional Field Creator
- National Accounts Management
- G/L Security
- G/L Consolidations
- Intercompany Transactions
- Process Server

More details of each module available on page 5 onwards.

Sage Accpac 100 ERP

Sage Accpac 100 ERP is an 'entry-level', scalable, web-based application designed for companies with up to five concurrent users and straightforward budget and account code segmentation requirements. This edition provides robust accounting and operation management tools alongside a secure path for future growth.

Smaller Businesses

Sage Accpac 200 ERP

Sage Accpac 200 ERP is ideal for medium-sized businesses that require up to ten concurrent users. Whilst providing all the features of Sage Accpac 100 ERP, this edition also offers increased functionality including unlimited company databases, 5 years of historical transaction retention and greater account code complexity to meet your increasing business requirements.

Medium sized Businesses

Sage Accpac 500 ERP

Sage Accpac 500 ERP offers all the functionality of Sage Accpac 200 ERP whilst supporting unlimited concurrent users. This edition is designed for medium-sized and larger businesses, typically operating with multiple locations and within a global marketplace. Sage Accpac 500 ERP retains up to 99 years of history, allows for unlimited account code structures and is ideal for companies requiring a functionally-rich, highly scalable system that supports international business infrastructures.

Larger Businesses

Sage Accpac ERP Feature Comparison

	Sage Accpac 100 ERP	Sage Accpac 200 ERP	Sage Accpac 500 ERP
Capacity			
Number of Users	Up to 5	Up to 10	Unlimited
Number of Companies	Up to 5	Unlimited	Unlimited
Number of Account Segments	2	3	10
Number of Account Structures	2	3	Unlimited
Number of Budgets	1	1	5
Years of History	2	5	99
User defined account groups	No	Yes	Yes
Financial Modules			
General Ledger	Yes	Yes	Yes
GL Consolidations	Yes – 500*	Yes – 500*	Yes – 500
GL Security	Yes – 500	Yes – 500	Yes – 500
Intercompany Transactions	Yes – 500	Yes – 500	Yes – 500
Transaction Analysis and Optional Field Creator	Yes	Yes	Yes
Purchasing Modules			
Purchase Orders	Yes	Yes	Yes
<i>Vendor Contract Costs</i>	No	Yes	Yes
Accounts Payable	Yes	Yes	Yes
Sales and Receivables Modules			
Order Entry	Yes	Yes	Yes
Accounts Receivable	Yes	Yes	Yes
<i>Advance Credit Claims (Receipt Entry)</i>	No	Yes	Yes
National Accounts Management	Yes – 500	Yes – 500	Yes – 500
Stock Management Modules			
Inventory Control	Yes	Yes	Yes
<i>Number of Item Segments</i>	4	10	10
<i>Multiple Levels of Bills of Material</i>	No	No	Yes
<i>Customer Item Numbers</i>	No	No	Yes
<i>Price by Unit of Measure</i>	No	No	Yes
<i>Price by Weight or Quantity</i>	No	No	Yes
<i>Price by a Cost Plus a Percentage or Amount</i>	No	No	Yes
<i>Below Cost or Sales Margin Price Checks</i>	No	No	Yes
Project Management Modules			
Project and Job Costing	Yes – 500	Yes – 500	Yes – 500
Timecard users	Yes – 500	Yes – 500	Yes – 500
Global Commerce Modules			
Multi-currency	Yes	Yes	Yes
Multiple languages	Yes	Yes	Yes
System and User Administration			
System Manager	Yes	Yes	Yes
Process Server	Yes – 500	Yes – 500	Yes – 500
Databases & Operating Systems			
MS.SQL, IBM DB2, Oracle, Pervasive.SQL	Yes	Yes	Yes
Linux, Windows, NT and Novell	Yes	Yes	Yes

*indicates that the module available from within the Sage Accpac 500 ERP edition is compatible with other edition.

Sage Accpac ERP modules are like mini-applications that can be added to your system without any disruption to your data or your core system. So, if one day you find you need to transfer and merge transaction information between separate company and branch office locations, simply add the appropriate module to your Sage Accpac ERP solution.

AVAILABLE MODULES:

System & User Administration

■ System Manager

The System Manager is the hub from which all other modules operate and it affects almost everything you do in your Sage Accpac ERP system - from establishing security to searching for a record within a file. This module includes effective tools that ensure data integrity and complete processing and security management as well as Crystal Enterprise for powerful reporting. System Manager also allows Sage Accpac ERP to run through a standard Web browser - without client software - centralising IT management and lowering overall ownership costs.

Some key capabilities of System Manager:

- Create analytical reports, graphs, charts, and budgets using Microsoft Excel
- Automate your bank reconciliation process
- Maintain all tax authorities and tax classes, and provide centralised tax reporting for Accounts Receivable, Accounts Payable, Order Entry, and Purchase Orders.
- Use security groups to control access to applications and specific functions within them and set up different user permissions for different applications.

- Use Microsoft Visual Basic for Applications for easy customisation and interaction with other Windows-based applications.
- Automate recurring General Ledger, Accounts Receivable, and Accounts Payable transactions with scheduling and Reminder List capabilities.
- Automatically restart batch operations, such as importing or posting, when they are not completed successfully.
- Easily resize forms and hide fields in forms for certain users.
- Run macros in a Web browser.

■ Process Server

The Process Server module allows you to off-load processor-intensive tasks to a computer (or a cluster of computers in high-volume environments) dedicated solely to providing processing services to client computers. In addition to providing the efficiencies of centralised processing, Process Server immediately frees-up client workstations, reduces network traffic, and lets you schedule exactly when the process server will begin its task, allowing you, for example to run process-intensive operations overnight.

Financial Modules

■ General Ledger

The General Ledger module is the foundation of your accounting system, designed to handle the most demanding budgeting and processing needs of organisations of all types and sizes.

Some key capabilities of Accpac General Ledger:

- Create alphanumeric account numbers as long as 45 characters.
- Flag General Ledger accounts as inactive to stop using them, but retain them in the system for historical and reporting purposes.
- Maintain separate periods for adjusting and closing entries.
- Assign different retained earnings accounts to different account segments.
- Set up and schedule recurring journal entries for transactions that are processed on a regular basis.
- Automatically create budgets using prior-year information or choose from seven other computation methods and lock budgets to prevent unauthorized changes.
- Create fast, flexible and customised analytical reports, statements, graphs and charts, and automatically update budgets through full integration with Microsoft Excel.
- Reverse a posted transaction.
- Consolidate transactions by account, fiscal period and source ledger.

■ General Ledger (G/L) Security Module

The G/L Security module enables organisations to control which users can view or use certain general ledger accounts based on segment validation in G/L Security settings.

Some key capabilities of G/L Security:

- Control access to any account in your general ledger by segment. This allows you to limit user activity to a prescribed set of accounts, blocking sensitive or confidential accounts from being seen or changed.
- Set access rights for single or multi-segment validation or for single or multiple e account validation.
- Restrict users from viewing batches containing accounts from which they are prohibited.

- Restrict users to adding accounts only to segments to which they have access. User restrictions can be added or removed at any time.
- Restrict financial reports only to valid accounts.

■ Transaction Analysis and Optional Field Creator Module

The Transaction Analysis and Optional Field Creator allows you to customise Sage Accpac ERP with unlimited additional fields and provide comprehensive reporting and analysis capabilities across your entire accounting system. You can define unlimited text, amount, date, time, integer, number, and yes / no optional fields for use across your whole Sage Accpac ERP system.

“By implementing Accpac into our structure, we were able to transition to a higher level business integration system and to control our administration processes in a more professional way. The benefits were quickly visible. Accpac provides the financial structure and controls that we require. One of the main advantages is that we can access data to build reports customized to our needs making our planning processes and market analyses easier and more efficient.”

Dr. Don Wassom, Managing Director, Heska AG, Switzerland
– a subsidiary of Heska Corporation.

■ General Ledger (G/L) Consolidations Module

G/L Consolidations lets you transfer and merge General Ledger account and transaction information between separate company and branch office locations. It is also designed to enable subsidiaries and holding companies to run without being on the same network or accounting database. G/L Consolidations allows you to define the level of detail to consolidate and provides a comprehensive audit trail. The system is available in two versions: a full version for the head office and a remote-sites version for branch offices.

Some key capabilities of G/L Consolidations Module:

- Consolidate multiple general ledgers by transactions, net period changes, or account balances.
- Consolidate general ledgers with differing fiscal years and fiscal periods, and with different account structures, using a mapping table.
- Maintain a separate general ledger for your consolidated ledgers or consolidate with the head office / central general ledger.
- Merge multiple accounts in subsidiaries into single holding company accounts.
- Automatically perform currency translation with the provision of gain or loss on translation.

- Consolidate multi-currency and single currency accounts, and general ledgers with differing functional currencies
- Translate amounts from functional currency or source currency in the originating ledger, and specify the translation rate type.

■ Multi-currency

The Multicurrency module delivers sophisticated currency management and the ability to process transactions in any number of currencies, essential to give your business the global competitive edge required in today's business world. Throughout Sage Accpac ERP, amounts are displayed in both source currency and functional currency, and the solution clearly distinguishes between the two on all screens.

Some key capabilities of Multicurrency:

- Unlimited currencies and rate types
- Print reports in both functional and source currencies
- Enter transactions and process payments and receipts in any currency.
- Restate outstanding source currency balances and transactions as exchange rates fluctuate with comprehensive currency revaluation.

■ Intercompany Transactions Module

Intercompany Transactions simplifies intercompany accounting. It lets you automatically distribute General Ledger and Accounts Payable transactions across two or more companies. In addition, its built in flexibility automatically generates intercompany loan account entries according to user-defined relationship tables, called routes.

Some key capabilities of Intercompany Transactions:

- Process intercompany General Ledger journal entries and intercompany Accounts Payable invoices, debit notes, and credit notes.
- Create an unlimited number of routes to define relationships between companies, including multilevel routes.
- Automatically make loan account entries for intercompany transactions and distribute invoices to as many General Ledger accounts as required by defining distribution sets.
- Fully integrate with Tax Services to handle tax computations for expensed, allocated, or recoverable taxes.
- Distribute transactions to companies with differing functional currencies.
- Create routes with originating companies, intermediate companies, and destination companies having different functional currencies.

Purchasing Modules

■ Accounts Payable Module

The Accounts Payable module provides robust accounting features to streamline your cash flow process and help you save money. Accounts Payable has a powerful library of accounting and reporting features that facilitate rapid entry of supplier invoices, flexible cash disbursement and full cheque reconciliation using Bank Services.

Some key capabilities of Accounts Payable:

- Force or withhold payment of individual transactions, controlling the maximum payment amount, and/or excluding specific suppliers.
- Organise supplier records quickly and easily, and flag inactive records that are retained for historical reporting.
- Create a new supplier and remit-to location when entering an invoice.
- Print cheques in English, French, and Spanish.

- Drill down from General Ledger transaction history to Accounts Payable transactions and then to originating Purchase Orders transactions and import transactions from other applications.
- Automatically distribute invoices to as many general ledger expense or asset accounts as you require by defining distribution sets.
- Set up and schedule recurring payables for invoices paid on a regular basis and automatically remind staff to process recurring payables.
- Track, calculate, and automatically retain a portion of an invoice to handle common billing practices in the construction industry.
- View your supplier payments by bank range, supplier range, cheque status, transaction type, date range, year and period range, and cheque number range.
- Pre-pay invoices that you have not yet received.
- Reinstate invoices by reversing posted cheques.
- Keep details of all fully paid transactions and print them when needed.

■ Purchase Order Module

When combined with Accounts Payable, Inventory Control, and Order Entry, the Purchase Orders module provides a comprehensive, fully integrated purchasing system. You can combine multiple purchase orders on a single receipt and multiple receipts on a single invoice. The Shippable Backorder report helps identify orders that can be completed based on recent Inventory Receipts.

Some key capabilities of Purchase Orders:

- Enter active, standing, future and blanket purchase orders.
- Use seven costing methods for the default item cost - Most Recent, Standard, Average, supplier, Last Unit, and two alternate amounts, for added flexibility.
- Enter details for requested items from multiple suppliers or without specifying suppliers on a single requisition, and then automatically create purchase orders for each supplier.
- Create one purchase order from multiple requisitions and select the requisition details by supplier number and Inventory Control supplier type.
- Quickly consolidate items from multiple purchase orders on a single receipt.
- Process multiple invoices for a single receipt.
- Designate non-inventory item numbers for one-time purchases, office supplies, and any non-inventory item.

- Automatically receive all items on a purchase order at once or receive partial purchase orders, entering quantities only for received items.
- Process adjustments to quantities, item costs and additional costs directly on the receipt or return, rather than as separate inventory adjustments.
- Allocate additional charges by quantity, weight, or cost, or manually specify the cost.
- Automatically produce purchase orders from Inventory Control reorder information or from Order Entry orders.
- Automatically drop ship items directly from the supplier to the customer.
- Enter additional costs such as freight or duty on a single receipt for received inventory items from multiple suppliers, and easily create a separate invoice for each supplier.
- Print requisitions, purchase orders, receiving slips, returns, and mailing labels using standard Purchase Orders formats, or design custom forms and reports using the built-in report writers.

Stock Management Modules

■ Inventory Control Module

Inventory Control is a complete multi-location inventory management system that keeps track of stock levels and processes inventory receipts, shipments, returns, and adjustments. Inventory Control includes extensive screen inquiry and reporting functions to give you the detailed, current information crucial for effective inventory management.

Some key capabilities of Inventory Control:

- Handle fractional quantities to four decimal places and maintain different units of measure for purchasing, selling, and stock-keeping.
- Use categories to classify stock and to allocate costs to departments or cost centres.
- Include 250-character comments with each transaction detail.
- Assign as many as nine suppliers per item with automatic update of the last purchase.
- Specify different item bin numbers for each inventory location.
- Assemble items using single-level bills of materials.

- Combine any number of items into a single kit and then sell the kit through Order Entry using a single kit price instead of a price per item.
- Receive both stock and non-stock items.
- Maintain as many as six different costs per location, including standard, most recent, average, last unit, and two optional user-defined costs.
- Cost items to six decimal places by moving average, FIFO, LIFO, standard, most recent, or user-specified costing methods.
- Allocate additional costs to transferred inventory items by quantity, cost, and weight, or manually specify the cost per item.
- Assign as many as five mark-up or five discount price levels per item and price list.
- Set pricing by percentage or amount, and by customer type or quantity purchased.
- Maintain separate price lists for different customer types, payment methods, regions, or currencies.
- Define an unlimited number of units of measure per item with fractional conversion factors.
- Review complete transaction history and drill down to the originating transactions in Inventory Control, Purchase Orders, and Order Entry.

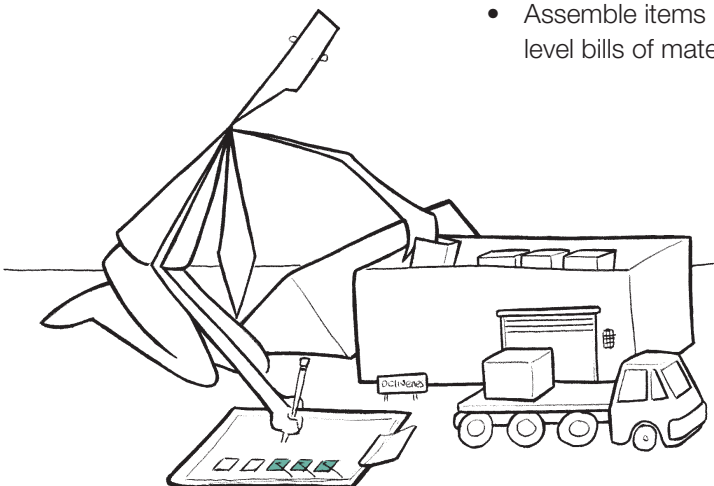

Sales and Receivables Modules

■ Accounts Receivable Module

With the Accounts Receivable module, you can manage your customers and fine-tune customer relations by keeping track of important sales information and outstanding balances. Accounts Receivable allows you to easily apply cash to outstanding invoices and create recurring charges for quick invoicing of monthly charges. Accounts Receivable is also fully integrated with Bank Services, for complete bank reconciliation.

Some key capabilities of Accounts Receivable:

- Organise customer records quickly and easily and create an unlimited number of ship-to locations for each customer.
- Drill down from General Ledger transaction history to Accounts Receivable transactions and then to originating Order Entry transactions

- Schedule any number of recurring charge invoices for fast invoicing of monthly charges, and update recurring charges automatically by amount or percentage
- Create adjustment batches automatically to write off small account or transaction balances, and choose whether to charge interest on overdue balances or individual invoices
- Track sales statistics for each salesperson.
- Track, calculate, and automatically retain a portion of an invoice to handle common billing practices in the construction industry.
- Print and review complete transaction details, including the details of receipts and adjustments applied to transactions, and keep a complete transaction history.
- View your customer receipts by bank range, customer range, receipt status, transaction type, date range, year and period range, and receipt number range.
- Perform on-screen aging and preview customer transactions.
- Review up-to-the-minute information including current balance, last activities and complete transaction details, and detailed statistics for each customer account.
- Send statements and invoices to your customer's billing address, customer's e-mail address, or contact's e-mail address.
- Create custom invoices, statements, and deposit slips.
- Set-up standard e-mail messages to automatically send to your customers with their documents
- Create a new customer and ship-to location when entering an invoice.



■ **Order Entry Module**

The Order Entry module allows you to enter orders and sales returns and print invoices, credit notes, order confirmations, picking slips, and shipping labels. You can track transaction details and sales information on-screen and in printed reports. Order Entry integrates fully with Inventory Control and Accounts Receivable, so you always know your inventory levels and the status of your customer accounts.

Some key capabilities of Order Entry:

- Enter active orders, future orders, standing orders, and quotes.
- Create an order by simply selecting and copying the details of existing customers' orders.
- Include multiple orders on a single shipment and multiple shipments on a single invoice.
- Ship items with or without first entering an order for those items.
- Edit and invoice partially shipped orders.
- Add new customers on the fly when you enter orders or add the customer records later.
- Assign sales proportionally to as many as five salespeople.
- Recall complete invoice information when issuing credit notes.
- Print packing slips, order confirmation, and invoices for selected orders and send them by email along with standard e-mail messages.
- Look up customer pricing based on customer contract price, item base price, or discounted or marked-up sales prices.
- Use prices with as many as six decimal places and include taxes in the selling price.
- Automatically determine available item quantities while entering orders.
- Review sales history by customer or inventory item during order and invoice entry.
- Easily customise order templates with standard information to help data entry.
- Set up any number of miscellaneous charges to speed invoicing.
- Specify whole or fractional quantities on orders.
- Enter order quantities using any unit of measure.
- Calculate commissions based on sales amount or margin.

■ **National Accounts Management Module**

National Accounts Management lets you use Accounts Receivable to process single payments from a customer's head office and apply it to the subsidiary accounts. The module also lets you limit the amount of credit you extend to a company in one step. During receipt entry, Accounts Receivable displays the transactions for all members of the national account at once, so you can quickly assign the payment to applicable customer accounts.

"The simplicity and robustness of Sage Accpac are assets which allow us to keep abreast of significant growth in transaction size and volume."

David Ball, Senior Finance Officer, The Global Fund

Project Management Module

■ Project and Job Costing Module

The Project and Job Costing module provides an effective solution for project managers in construction and other professional industries who require a time-and-material system. It makes the estimating, tracking, costing, and billing of projects easy and manageable—simplifying cost control and planning. With the powerful features of Project and Job Costing you can identify potential issues and determine success factors for any project. Automated billing streamlines customer invoicing, reducing the time spent managing this process.

Some key capabilities of Project and Job Costing:

- Assign staff, material, subcontractors, equipment, miscellaneous items, and overhead to each project within the contract.
- Set up complex estimates by specifying the quantity (e.g., hours), unit cost, and billing rate (for time-and-materials projects) for each staff member, material (inventory item), subcontractor, equipment, miscellaneous item, and overhead expense allocated to the project.
- Assign cost categories and automatically calculate cost and revenue estimates per cost category, or simply define the cost and revenue estimates for each project category.
- Manage contracts or jobs to three levels—contract (job), project (phase), and category. Then maintain multiple projects within each contract and track multiple categories within each project.
- Change contract, project, and category names to match industry-specific terminology.
- Use as many as five segments in your contract numbers to represent types of contracts and divisions.
- Choose from three different project types—time and materials, cost-plus, and fixed price.
- Assign each category to one of six cost types (labour, material, equipment, miscellaneous, overhead, and subcontractor) to track costs at a level necessary for your company.
- Automatically override General Ledger revenue account segments for each project and cost account segments for each category.
- Track, calculate, and automatically retain a portion of an invoice to handle common billing practices in the construction industry.
- Automatically create the customer's invoice based on the transactions that are due to be billed. Review the generated billings for the customer and make necessary changes before updating Accounts Receivable.
- Transfer inventory items to a contract, project, and category and bill the customer for the inventory used.
- Return inventory items not used in the project to inventory for availability on other projects.
- Allow employees to easily manage their time and billing records from any location (on site or at the office) by entering timecards using an Internet browser.

"We at Guylian (UK) Ltd chose to deploy Accpac to record our management accounts. The on-going local support for our Accpac solution has been great. We find the solution easy to use and were up and running in our office surprisingly quickly. Accpac is now also used in a number of other Guylian offices around the world".

Kevin Toms, Managing Director, Guylian (UK) Ltd

Sage Accpac Options are a set of solutions designed to extend the value and performance of your Sage Accpac system with a variety of reporting, analysis, automation, and feature extension tools. These include:

Account Code Change – allows you to easily change, combine and copy account codes and change account structures while still maintaining historical transactions.

Accpac Alerts Server – a tool that relies on 'trigger activities' to automatically communicate specified activities to appropriate customers, employees, or business partners. An example would be an alert sent to a purchasing clerk when the stock of a certain item becomes low.

Accpac ODBC Link – allows you to connect to one or more Sage Accpac ERP databases. Using popular Windows-based products such as Microsoft Access, Microsoft Excel, Lotus 1-2-3, and Crystal Reports, you can gain access to your data in ways never before possible.

Accpac Query – a user-friendly, wizard-driven report writer that helps you easily generate the reports you need to run your business.

Accpac Zippy Notes – allows you to annotate records in your database, providing additional information about customers, stock and procedures. It allows users to attach an electronic 'sticky note' to a field; the note will pop up whenever anyone accesses the field, even across different applications.

Contract Number Change – easily change contract numbers within the Project & Job Costing module while still maintaining historical transactions.

Customer Number Change – easily change, combine, and copy customer numbers while still maintaining historical transactions.

Financial Link Professional – a flexible report designer with powerful formatting features that transforms general ledger data into pixel perfect presentation quality statements and reports.

Item Number Change – easily change, combine and copy item numbers and change item number structures while still maintaining historical transactions.

Lot Tracking – manage your lot numbers from receipt in Purchase Orders through Order Entry shipment with full integration. By entering lot numbers during standard transaction processing, you have one point of entry for faster, safer, simpler and smarter lot number management. This module integrates with Purchase Orders, Inventory Control, Order Entry, Accounts Receivable and Accounts Payable.

Sales Analysis – keeps a complete online database of your customer and item sales history.

Serialized Inventory – designed to track serial numbers from the point of receipt through to the point of sale.

Vendor Number Change – easily change, combine, and copy vendor numbers while still maintaining historical transactions.

For full details of these modules, please contact us.

Your Sage Business Partner:



System Requirements

The hardware requirements for Sage Accpac ERP will vary depending on the usage pattern on each workstation. Please see www.sage.co.uk or consult your Sage Business Partner for details.

This publication is not intended to form any contract for computer software with Sage (UK) Limited or any of its subsidiaries ('Sage'). If you require a particular application or feature, the suitability of the Program should be verified.

We make every effort to ensure that the contents of this, and all other Sage publications, are correct and accurate. This publication is for information purposes only and is not intended to form the basis of any contract for the sale or purchase of the product being described. No liability for errors will be accepted.



Sage (UK) Limited,
North Park,
Newcastle upon Tyne,
NE13 9AA

Tel 0845 111 9988
Fax 0845 245 0297
www.sage.co.uk